

201 FAIRWAY TOWNHOMES

BRYAN, TEXAS

ARCHITECT:
R.A.I. DESIGNS, INC.
 4500 CARTER CREEK
 SUITE 203
 BRYAN, TEXAS 77802
 (979) 846-3366

OWNER:
LIONS PARK PROPERTIES, LLC
 1580 COPPERFIELD PARKWAY
 COLLEGE STATION, TEXAS 77845
 (979) 690-7383

STRUCTURAL ENGINEER:
MLAW ENGINEERS
 2804 LONGHORN BLVD.
 AUSTIN, TEXAS 78758
 (512) 835-7000

BUILDING CODE DATA	
BUILDING CODE:	THE INTERNATIONAL BUILDING CODE (2021 EDITION) w/ ADOPTED AMENDMENTS
ACCESSIBILITY CODE:	TEXAS ACCESSIBILITY STANDARDS
PLUMBING CODE:	THE INTERNATIONAL PLUMBING CODE (2021 EDITION) w/ ADOPTED AMENDMENTS
MECHANICAL CODE:	THE INTERNATIONAL MECHANICAL CODE (2021 EDITION) w/ ADOPTED AMENDMENTS
ELECTRICAL CODE:	THE NATIONAL ELECTRICAL CODE (2020 EDITION) w/ ADOPTED AMENDMENTS
ENERGY CODE:	THE INTERNATIONAL ENERGY CONSERVATION CODE (2018 EDITION) w/ ADOPTED AMENDMENTS
FIRE PREVENTION CODE:	THE INTERNATIONAL FIRE CODE (2021 EDITION) w/ ADOPTED AMENDMENTS
TYPE OF CONSTRUCTION:	TYPE V-B
OCCUPANCY CLASSIFICATION:	MULTI-FAMILY

201 FAIRWAY UNIT AREA SUMMARY	
UNIT ONE	
1st FLOOR LIVING	1,110 SF
2nd FLOOR LIVING	945 SF
TOTAL UNIT LIVING	2,055 SF
FRONT PORCH	27 SF
OUTDOOR LIVING	80 SF
UNIT TWO	
1st FLOOR LIVING	1,110 SF
2nd FLOOR LIVING	945 SF
TOTAL UNIT LIVING	2,055 SF
FRONT PORCH	25 SF
OUTDOOR LIVING	77 SF
UNIT THREE	
1st FLOOR LIVING	1,091 SF
2nd FLOOR LIVING	1,176 SF
TOTAL UNIT LIVING	2,267 SF
FRONT PORCH	27 SF
OUTDOOR LIVING	81 SF
TOTAL FRAMED	6,694 SF
TOTAL SLAB	3,627 SF

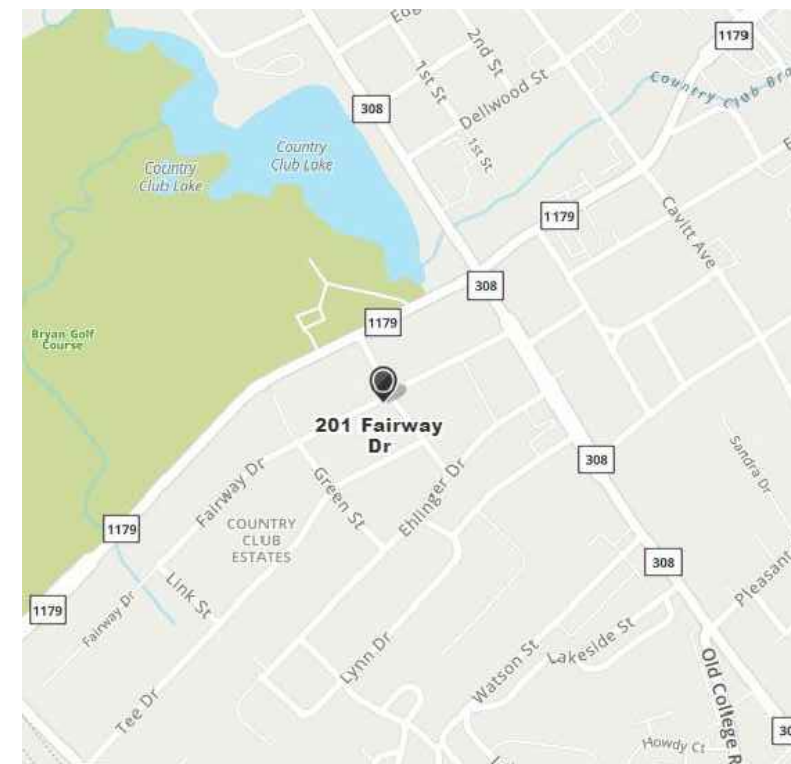

VICINITY MAP
SCALE: N.T.S.

SHEET INDEX	
COVER SHEET	S-1
SITE PLAN	S-2
LANDSCAPING PLAN	S-3
DETAILS	S-4

© COPYRIGHT 2022 BY R.A.I.
 (979) 846-3366
 4500 Carter Creek Dr. #203
 Bryan, TX 77802
 www.raidesigns.com

R.A.I.
 DESIGNS, INC.

JOB# 21-078

PROJECT SITE INFO:
 201 FAIRWAY BRYAN, TEXAS
 COUNTRY CLUB ESTATES SUBDIVISION
 LOTS 1R-1, 1R-2, 1R-3 BLOCK-D
 0.532 ACRES

CLIENT:
**LIONS PARK
 PROPERTIES, LLC,
 TERENCE MURPHY**
 (979) 690-3783

08-11-22
 08-15-22

JTR- TOWN HOME LAYOUT
 JTR- THIRD SUBMITTAL

SHEET:
S-1
 OF
 FOUR
 DATE:
 08-24-2022

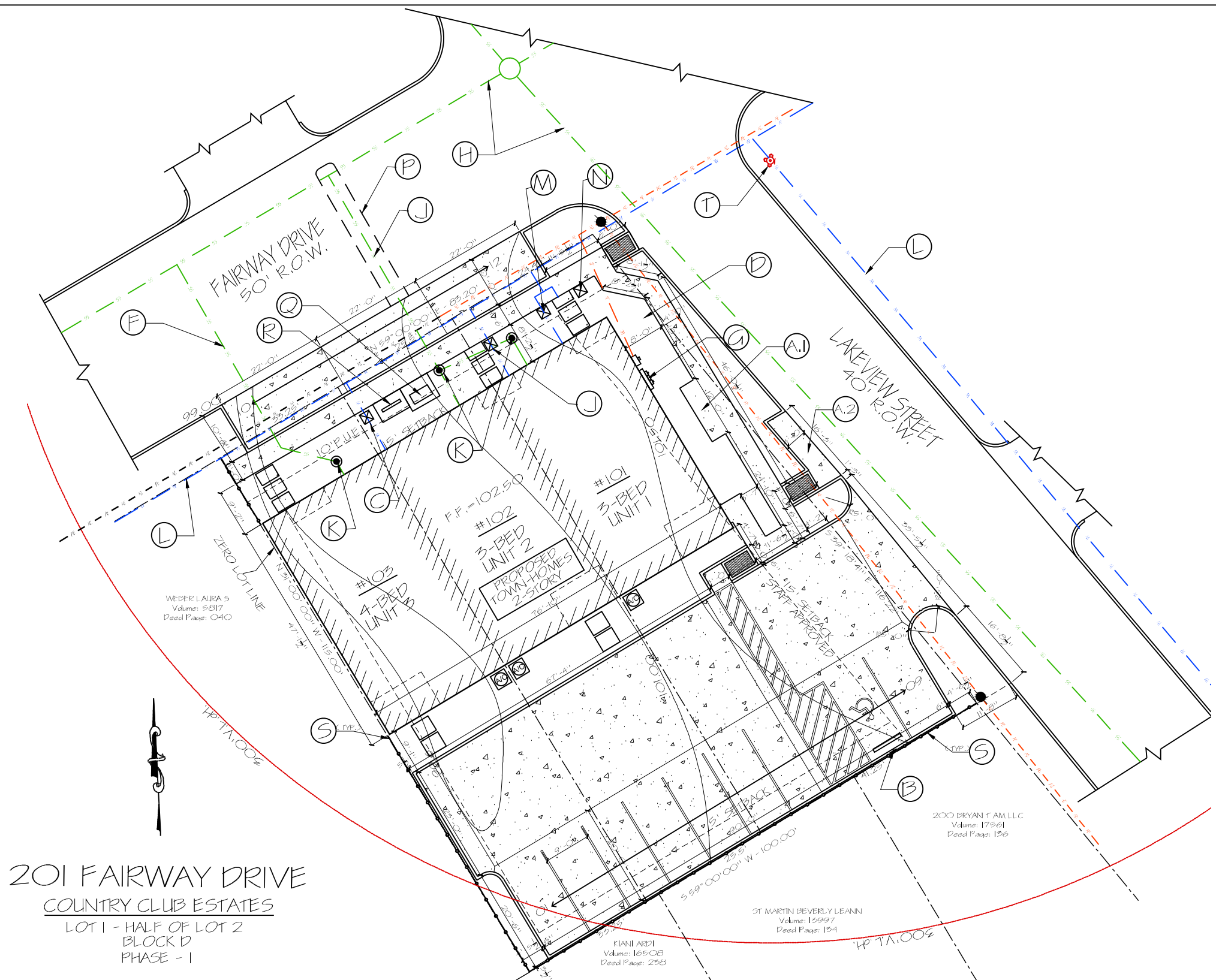

201 FAIRWAY DRIVE
COUNTRY CLUB ESTATES
LOT 1 - HALF OF LOT 2
BLOCK D
PHASE - 1

SITE PLAN

SCALE: 1" = 10'-0" | 04

SITE SCHEDULE	
TAG	ITEM
○	SOLID WASTE - LOCATION OF 3 ROLL-OFFS WHEN NOT BY STREET
○	SOLID WASTE - LOCATION OF 3 ROLL-OFFS ON PICK-UP DAY
○	HANDICAP PARKING SIGN
○	EXISTING WATER METER TO BE RE-LOCATED AND USED
○	ELECT. - PRIMARY ELECT. SERVICE: 2-4" PVC CONDUIT (GREY) w/ FULL STRING (MIN. 46" COVER)
○	ELECT. - SECONDARY SERVICE: 2-4" PVC CONDUIT (GREY) w/ FULL STRING (MIN. 26" COVER)
○	SEWER - EXISTING 4" SANITARY SEWER LINE, RE-USED
○	ELECT. - METER BOXES - BY UNIT
○	SEWER - EXISTING 6" SANITARY SEWER LINE
○	SEWER - NEW 4" SANITARY SEWER LINE
○	SEWER - CLEAN OUT (TYPICAL)

NOTE: ALL SITE DETAILS TO MEET B/C S.U.D.O. REQUIREMENTS. ALL SELECTIONS TO BE MADE BY OWNER BEFORE CONSTRUCTION BEGINS.

SITE SCHEDULE

SCALE: N.T.S. | 03

- SITE NOTES**
- THIS PROPERTY DOES NOT LIE WITHIN A 100-YEAR FLOODPLAIN PER FEMA D-FIRM PANEL NO. 48041C0215F, DATED APRIL 2, 2014.
 - FOR UTILITY NOTIFICATION CONTACT
BTU - (979) 821-5700
CITY OF BRYAN - (979) 209-5900
 - 2-HOUR FIRE WALL SEPARATIONS WILL BE PROVIDED FOR EACH UNIT.
 - OFF-SITE DRAINAGE SHALL BE CONTROLLED BY DRAINAGE SWALES AND BEING DETAINED IN THE DRIVE ANGLES. BY DOING THIS THE NEIGHBORING PROPERTIES WILL NOT BE AFFECTED.
 - WHERE ELECTRIC FACILITIES ARE INSTALLED, BTU HAS THE RIGHT TO INSTALL, OPERATE, RELOCATE, CONSTRUCT, RECONSTRUCT, ADD TO, MAINTAIN, INSPECT, PATROL, ENLARGE, REPAIR, REMOVE AND REPLACE SAID FACILITIES UPON, OVER, UNDER AND ACROSS THE PROPERTY INCLUDED IN THE PUE, AND THE RIGHT OF INGRESS AND EGRESS ON PROPERTY ADJACENT TO THE PUE TO ACCESS ELECTRIC FACILITIES.
 - PLEASE HAVE CONTRACTOR CONTACT BTU LINE DESIGN AT 821-5770 120 DAYS BEFORE POWER IS NEEDED TO BEGIN THE PROCESS OF OBTAINING POWER TO THE SITE. PLEASE PROVIDE A DETAILED LOAD ANALYSIS, AS WELL AS THE SERVICE REQUIREMENTS (VOLTAGE, AMPS, SINGLE PHASE VS THREE PHASE) AT THIS TIME.
 - THIS PROPERTY IS ZONED MIDTOWN - CORRIDOR DISTRICT (MT-C). CURRENTLY ZONED RESIDENTIAL DISTRICT (RD-5).
 - ALL SETBACKS WILL BE CONSISTENT WITH THE LOT DEVELOPMENT STANDARDS FOUND IN LAND AND SITE DEVELOPMENT ORDINANCE SECTION 62-593, EXCEPT FOR THE STAFF LEVEL APPROVED SIDE SETBACK VARIANCE.
 - NO MECHANICAL EQUIPMENT SHALL BE VISIBLE FROM THE PUBLIC RIGHT-OF-WAY.
 - POTENTIALLY HARMFUL NEGATIVE IMPACTS FOR THIS PROJECT WILL BE MITIGATED BY HAVING A 6'-0" SCREENING AROUND THE PARKING LOT AND ANGLING THE SECURITY LIGHTS PROPERLY.

PARKING RATIO CALCULATIONS

3-BEDROOMS PER UNIT	02 TOTAL UNITS
4-BEDROOMS PER UNIT	01 TOTAL UNITS
10 x 1.0 = 10 TOTAL SPACES REQUIRED	
09 SPACES PROVIDED ON THE PROPERTY AND 03 ARE PROVIDED IN THE RIGHT-OF-WAY	TOTAL = 12

NOTES SCALE: N.T.S. | 02

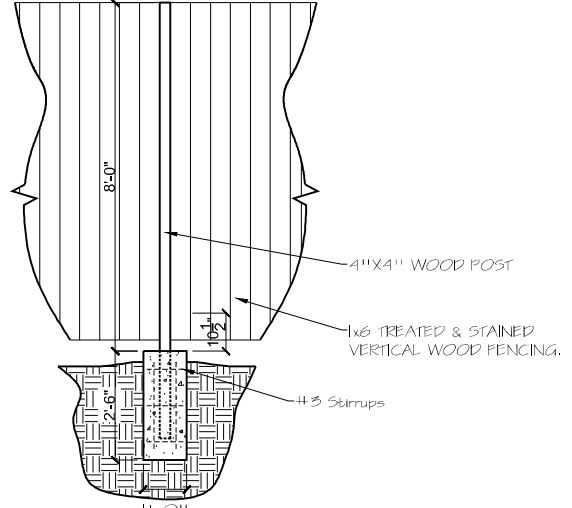

OPAQUE FENCE DETAIL

SCALE: 1/2" = 1'-0" | 01

R.A.I. DESIGNS, INC.
(979) 846-3366
4500 Carter Creek Dr. #203
Bryan, TX 77802
www.raidesigns.com

R.A.I. DESIGNS, INC.

JOB# 21-078

PROJECT SITE INFO:
201 FAIRWAY BRYAN, TEXAS
COUNTRY CLUB ESTATES SUBDIVISION
LOTS 1R-1, 1R-2, 1R-3 BLOCK-D
0.532 ACRES

CLIENT:
LIONS PARK PROPERTIES, LLC,
TERRENCE MURPHY
(979) 690-3783

JTR - TOWN HOME LA YOUT	08-11-22
JTR - THIRD SUBMITTAL	08-15-22
SHEET: S-2 OF FOUR	DATE: 08-24-2022

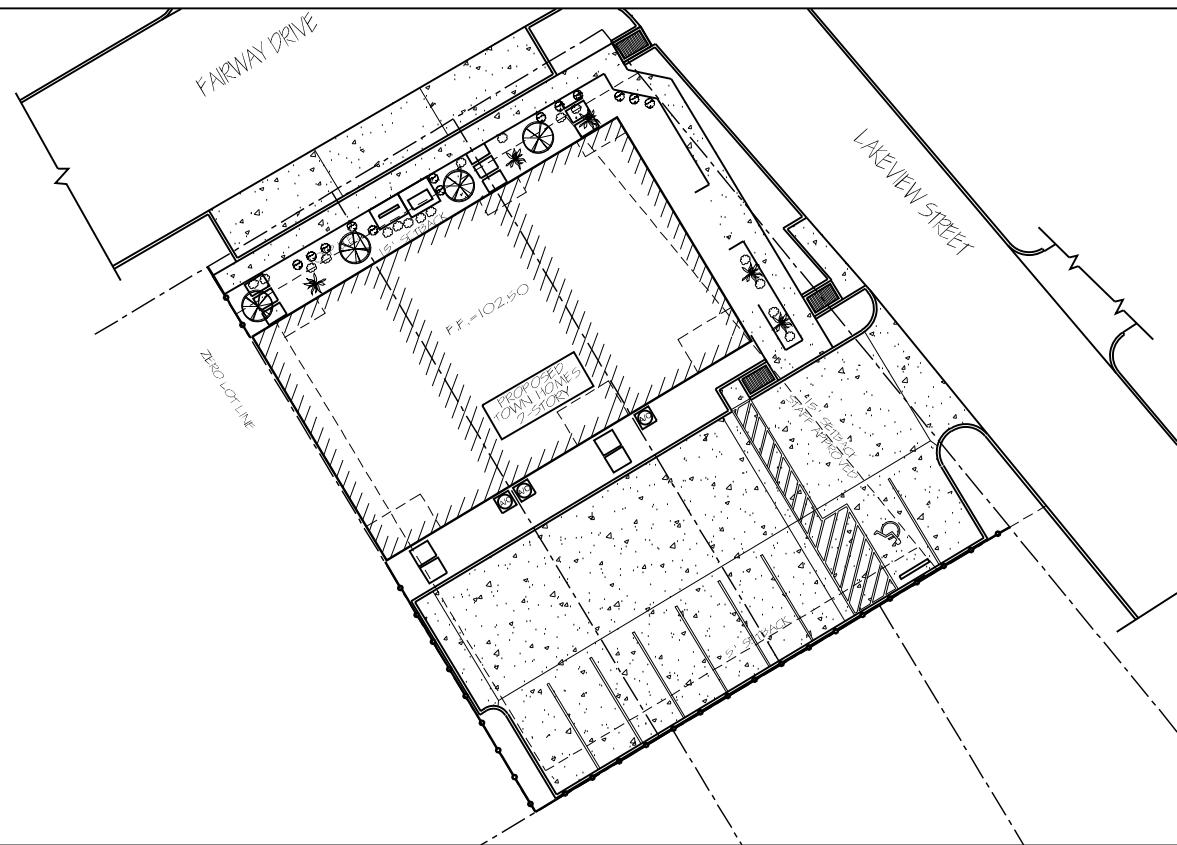

LANDSCAPING REQUIREMENTS

TOTAL SQUARE FEET OF THE SITE = 10,534
 22,755 x .15% = 1,580
 THERE ARE A TOTAL OF 1,580 LANDSCAPING POINT REQUIRED FOR THIS PROJECT.

TOTAL PROVIDED 1,860.

THE TOTAL LANDSCAPING REQUIREMENTS AMOUNT OF 15% MEETS THE MINIMUM 15% REQUIRED.

LANDSCAPING SCHEDULE								
SYMBOL	NO. OF PLANTS	SIZE	BOTANICAL NAME	COMMON NAME	TYPE	NOTES	POINTS EACH	TOTAL POINTS
	4	1.5" to 5.0" CALIPER	TAXODIUM DISTICHUM	BALD CYPRESS	CANOPY TREE	50 GALLON	200	800
	5	1.5" to 5.0" CALIPER	AGAVE AMERICANA	BLUE AMERICAN AGAVE	ORNAMENTAL NON-CANOPY TREE	15 GALLON	150	750
	15	5 GALLON	LEUCOPHYLLUM FRUTESCENS "GREENWOOD"	GREENWOOD TEXAS SAGE	SHRUB	<18" HEIGHT	10	150
	13	5 GALLON	ERICACEAE THEACEAE	CAMELLIA	SHRUB	<24" HEIGHT	10	180
								1,860

LANDSCAPING PLAN

SCALE: N.T.S. | 03

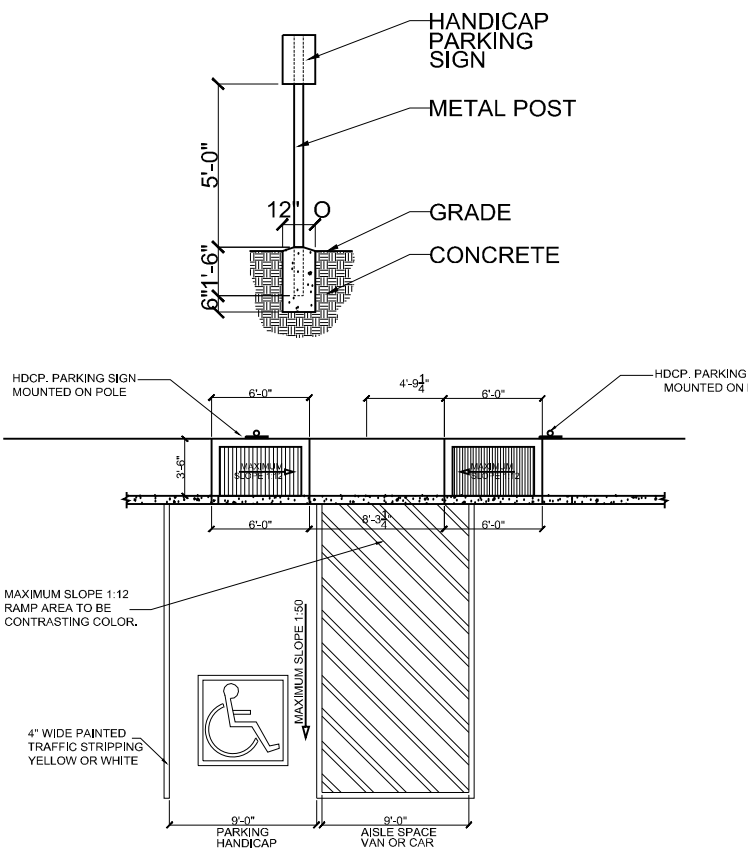

HANDICAP PARKING DETAILS

SCALE: N.T.S. | 02

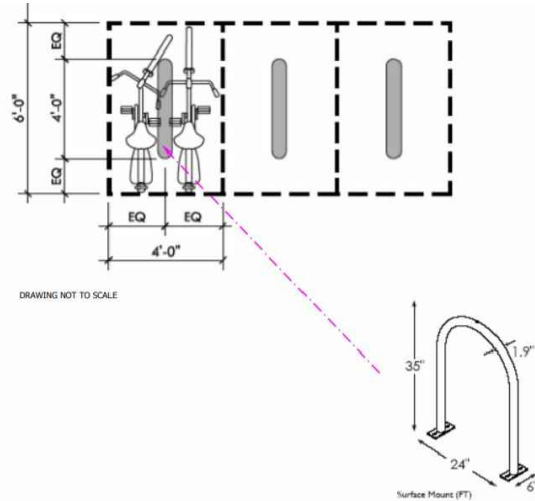

SITE DETAILS

BUILDING CODE DATA	
BUILDING CODE:	THE INTERNATIONAL BUILDING CODE (2021 EDITION) w/ ADOPTED AMENDMENTS
ACCESSIBILITY CODE:	TEXAS ACCESSIBILITY STANDARDS
PLUMBING CODE:	THE INTERNATIONAL PLUMBING CODE (2021 EDITION) w/ ADOPTED AMENDMENTS
MECHANICAL CODE:	THE INTERNATIONAL MECHANICAL CODE (2021 EDITION) w/ ADOPTED AMENDMENTS
ELECTRICAL CODE:	THE NATIONAL ELECTRICAL CODE (2020 EDITION) w/ ADOPTED AMENDMENTS
ENERGY CODE:	THE INTERNATIONAL ENERGY CONSERVATION CODE (2018 EDITION) w/ ADOPTED AMENDMENTS
FIRE PREVENTION CODE:	THE INTERNATIONAL FIRE CODE (2021 EDITION) w/ ADOPTED AMENDMENTS
TYPE OF CONSTRUCTION:	TYPE V-B
OCCUPANCY CLASSIFICATION:	MULTI-FAMILY

SCALE: N.T.S. | 01

© COPYRIGHT 2022 BY R.A.I.
 (979) 846-3366
 4500 Carter Creek Dr. #203
 Bryan, TX 77802
 www.raidesigns.com

R.A.I.
 DESIGNS, INC.

JOB# 21-078

PROJECT SITE INFO:
 201 FAIRWAY BRYAN, TEXAS
 COUNTRY CLUB ESTATES SUBDIVISION
 LOTS 1R-1, 1R-2, 1R-3 BLOCK-D
 0.532 ACRES

CLIENT:
 LIONS PARK
 PROPERTIES, LLC,
 TERENCE MURPHY
 (979) 690-3783

JTR- TOWN HOME LA YOUT
 JTR- THIRD SUBMITTAL
 08-11-22
 08-15-22

SHEET:
 S-3
 OF
 FOUR
 DATE:
 08-24-2022

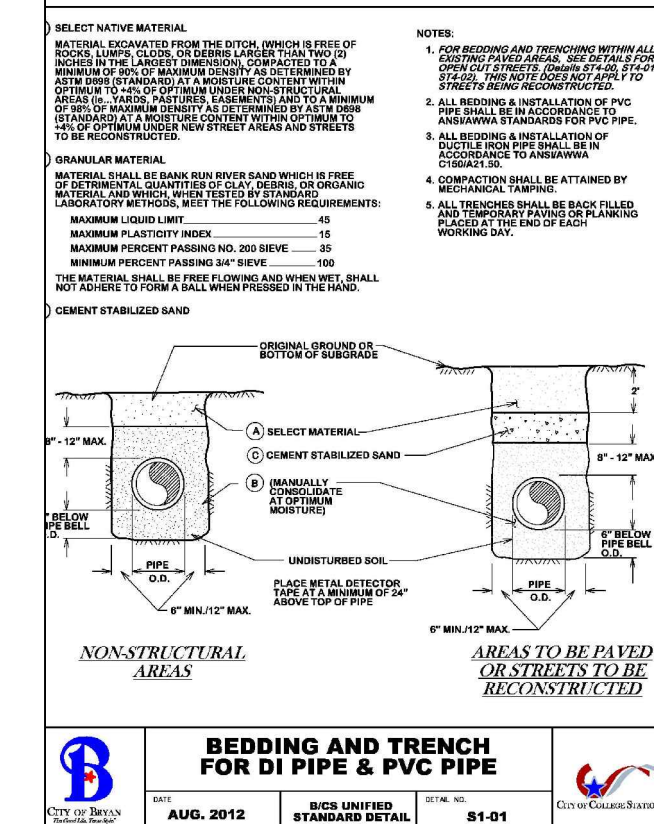
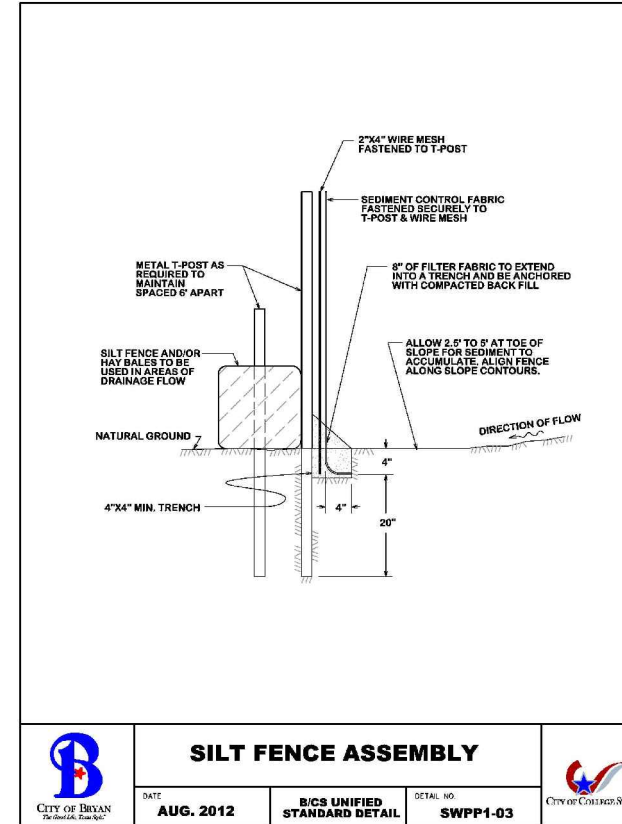
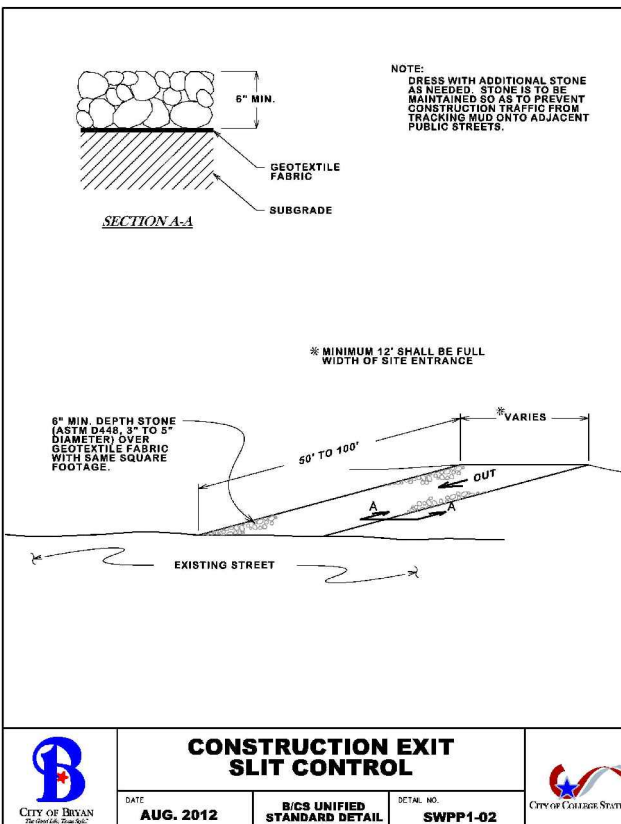
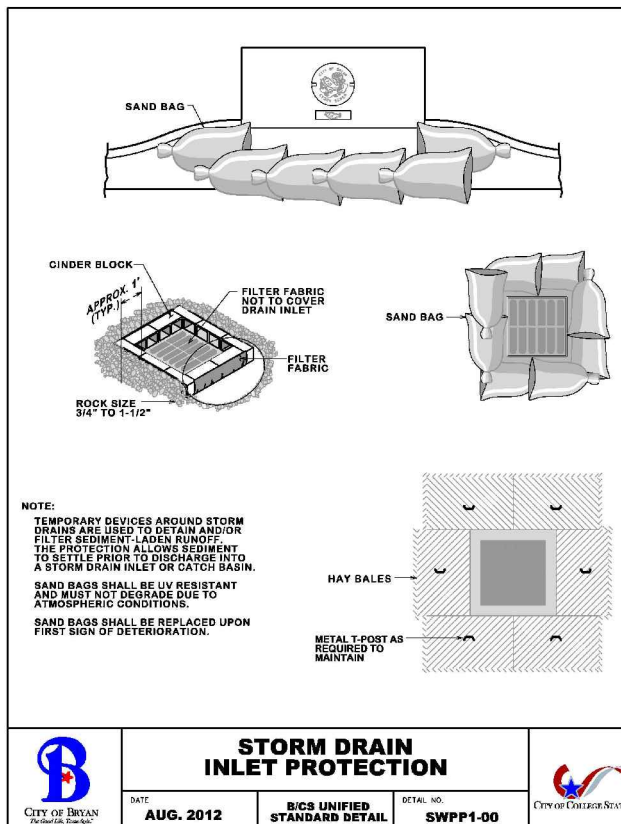
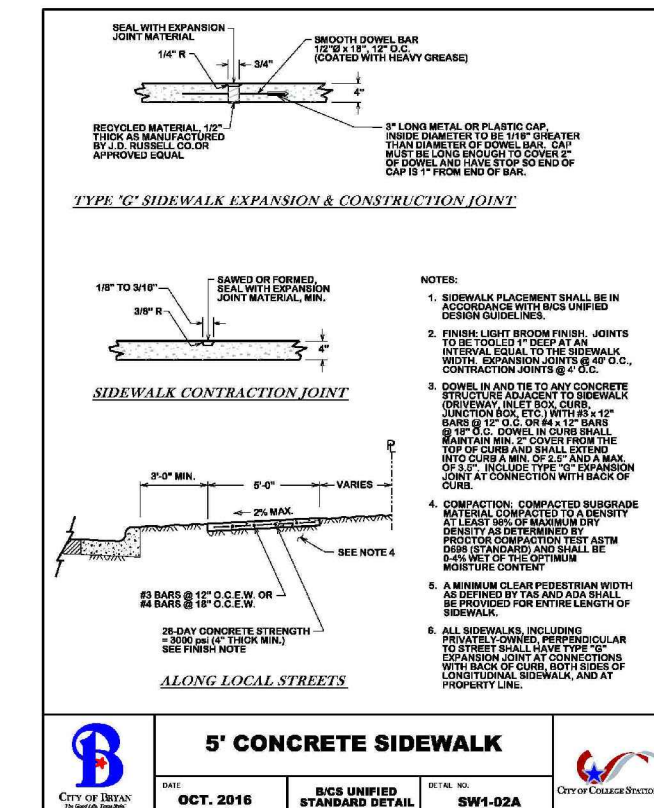
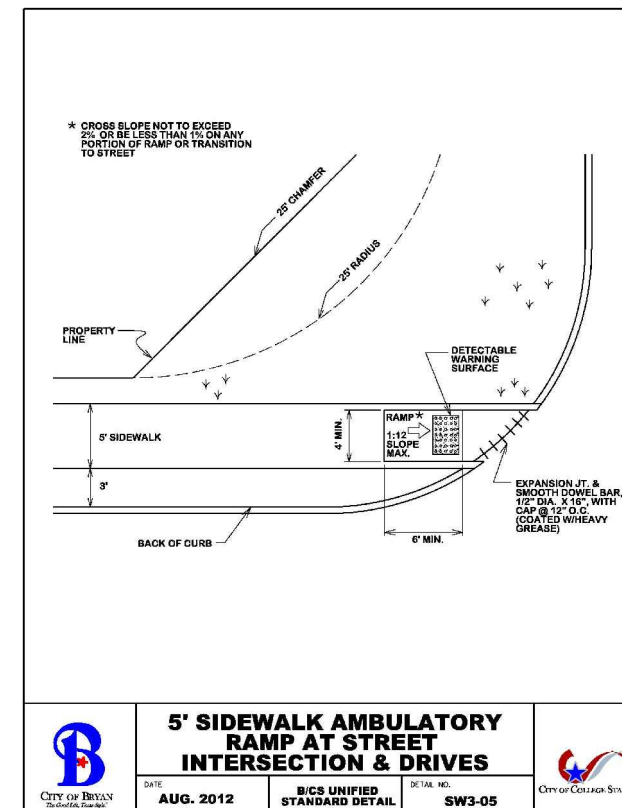
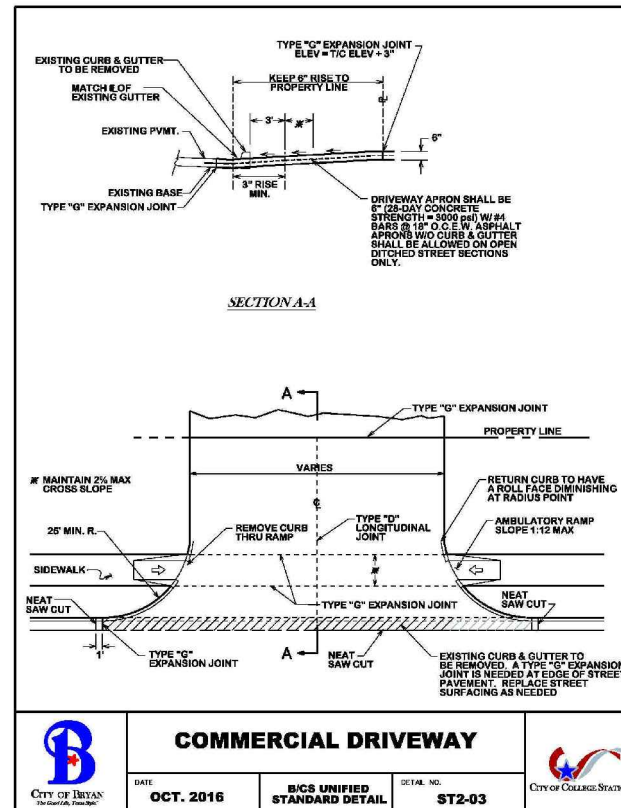
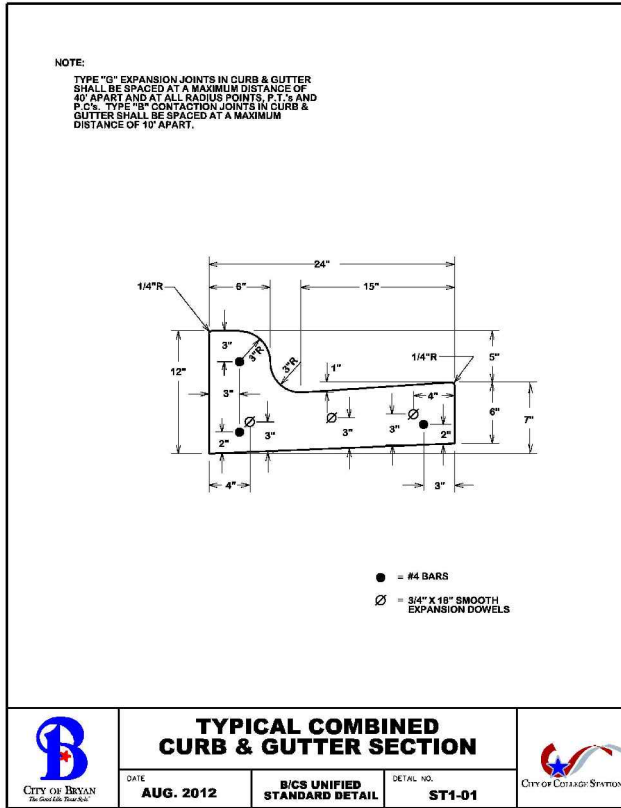

JTR- TOWN HOME LA YOUT	08-11-22
JTR- THIRD SUBMITTAL	08-15-22